

# Molde

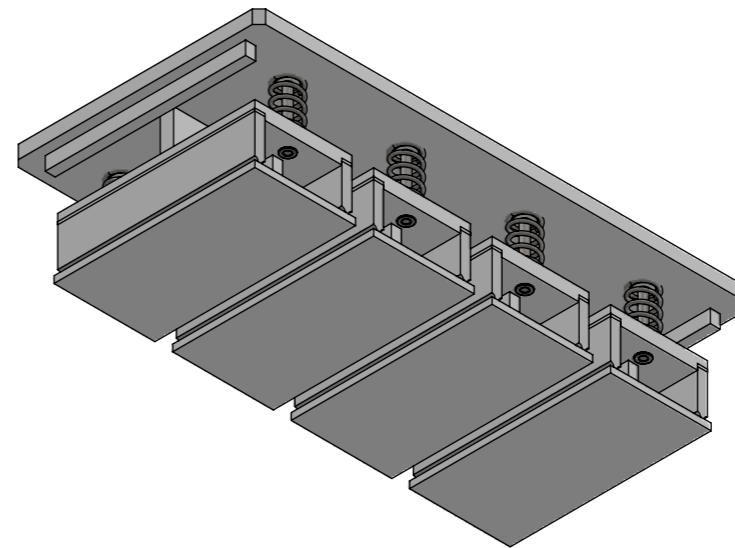

# Tapa

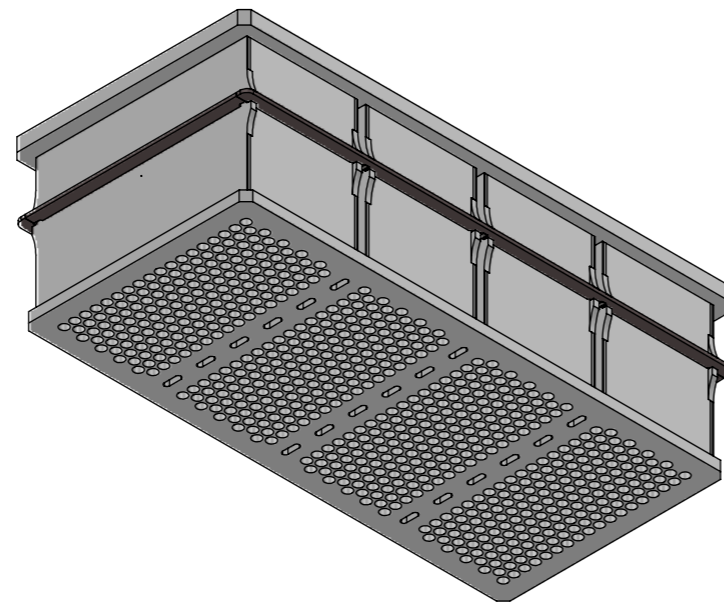
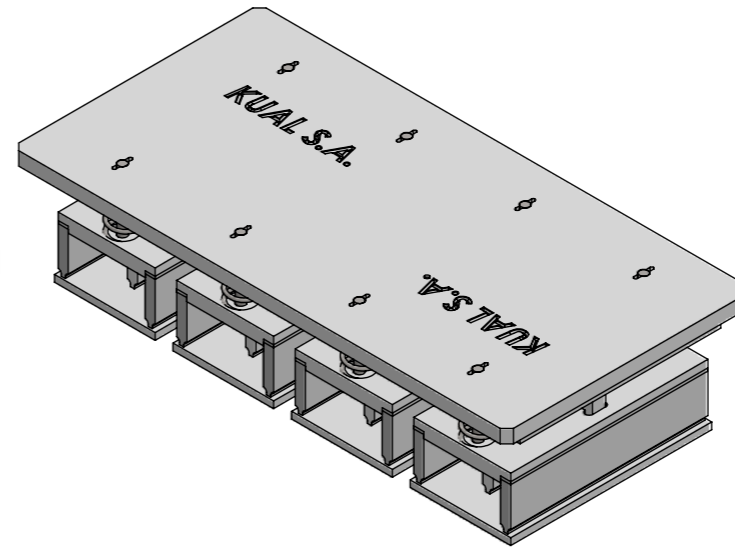
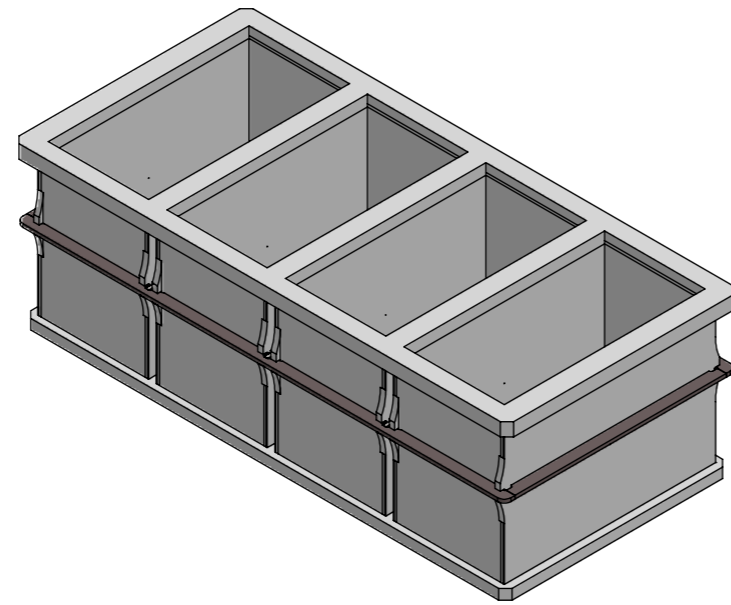
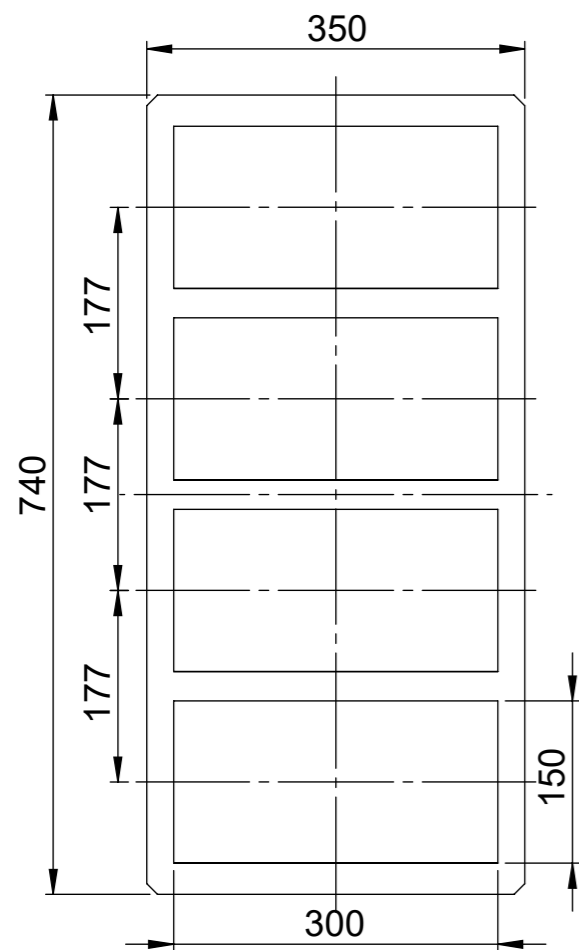
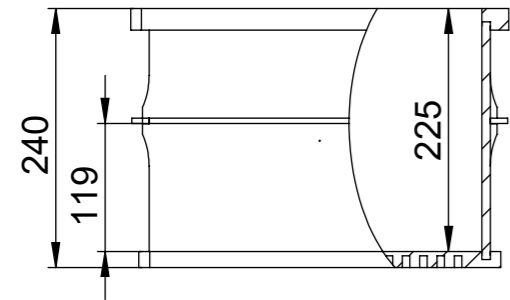
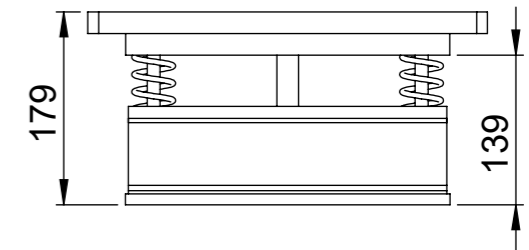
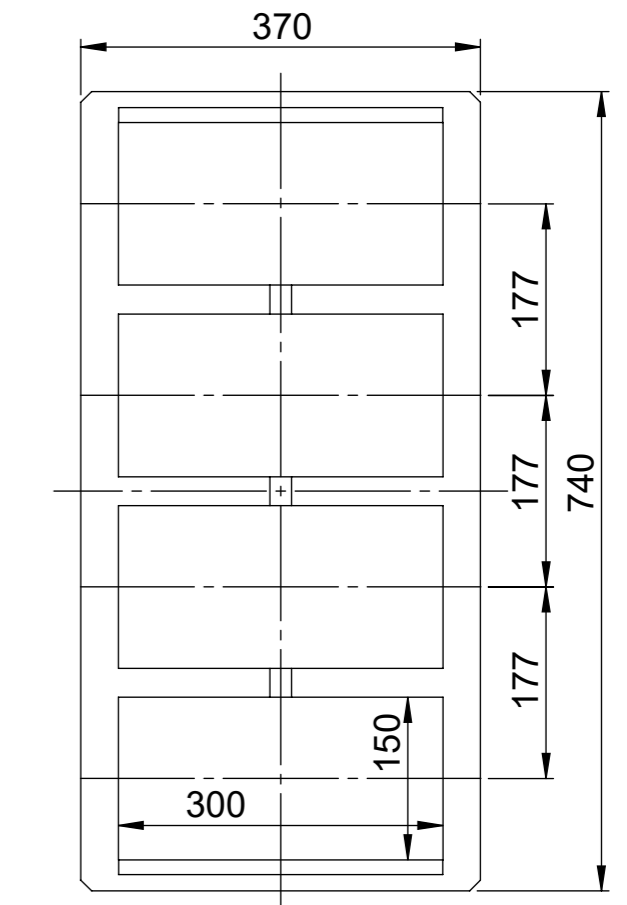

# Limite de prensado

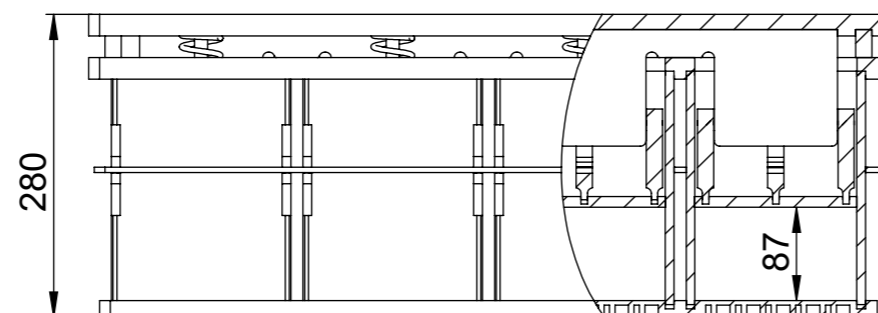

Tolerancias generales			Plano	
Medida nominal inferior	0	300	Multimolde rectangular de 4 unidades x (300 x 150 x 225) mm	
Medida nominal superior	300	1000	<b>Material</b>	<b>Peso</b>
Tolerancia	±0.5	±1	KUAL-HQ-PE-HD	29,0 kg
<b>Escala</b>	1:7	<b>Denominación</b>		
		300 x 150 x H225 x 4U		
<b>Unidades en mm.</b>	This drawing is our exclusive property and it may not be reproduced, copied or loaned in part or whole, without our written authority.		Este plano es propiedad exclusiva y no debe ser reproducido, copiado o prestado en parte o en su totalidad, sin nuestra autorización escrita.	
<b>A3</b>				