

Molde

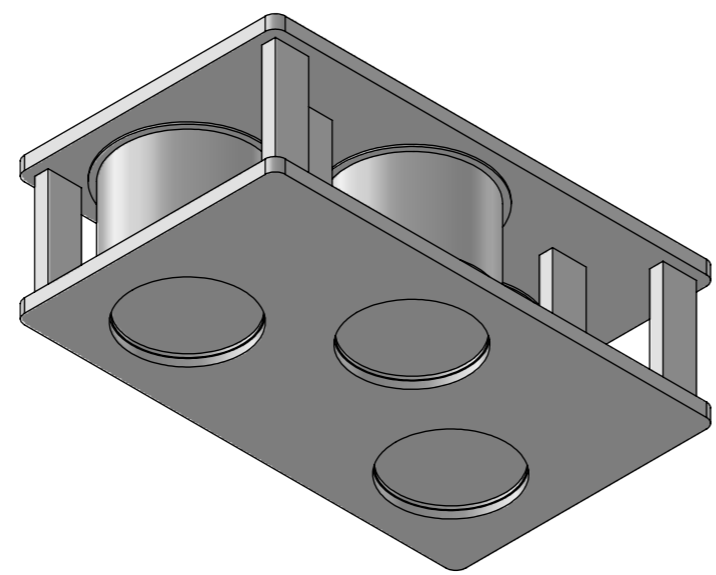

Tapa

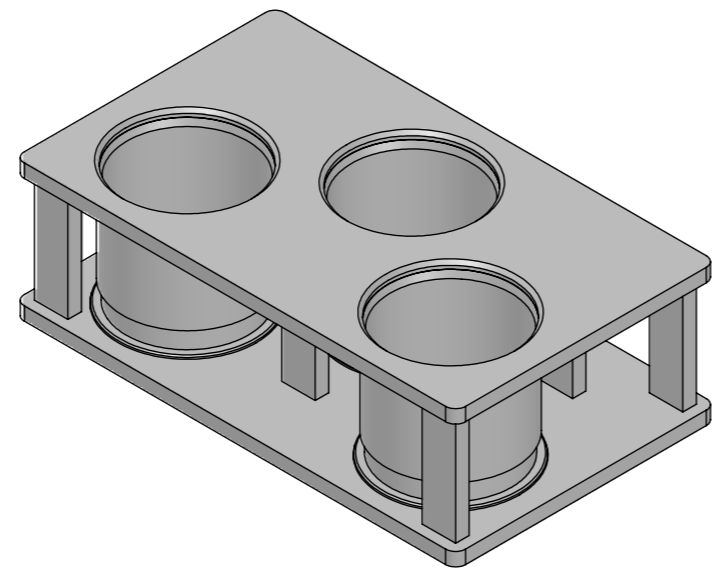
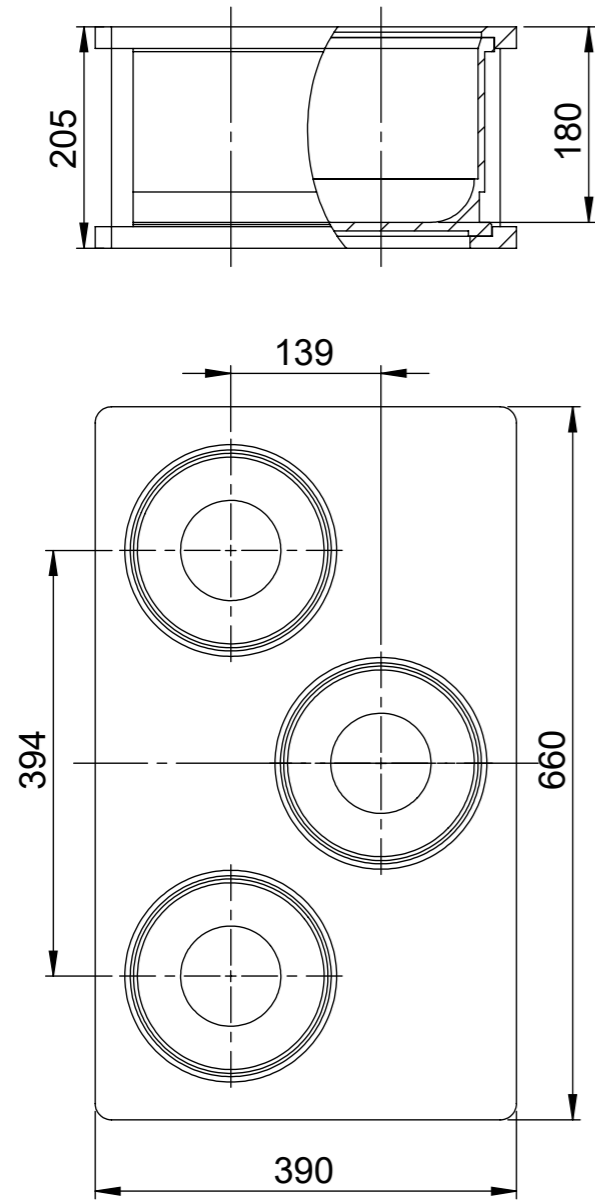
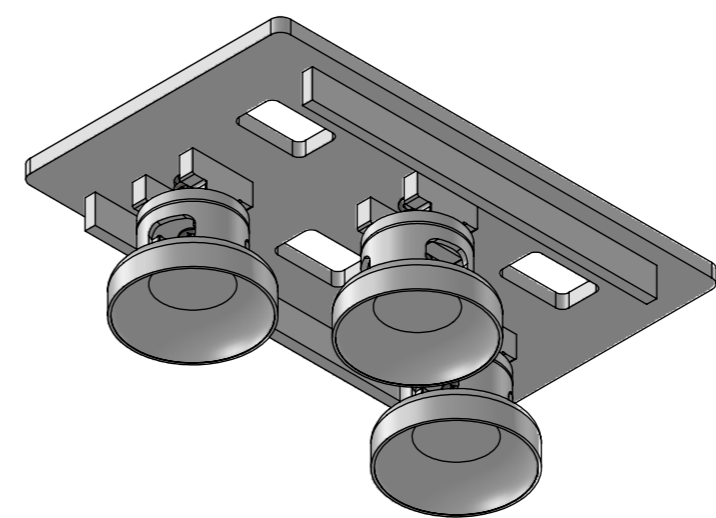
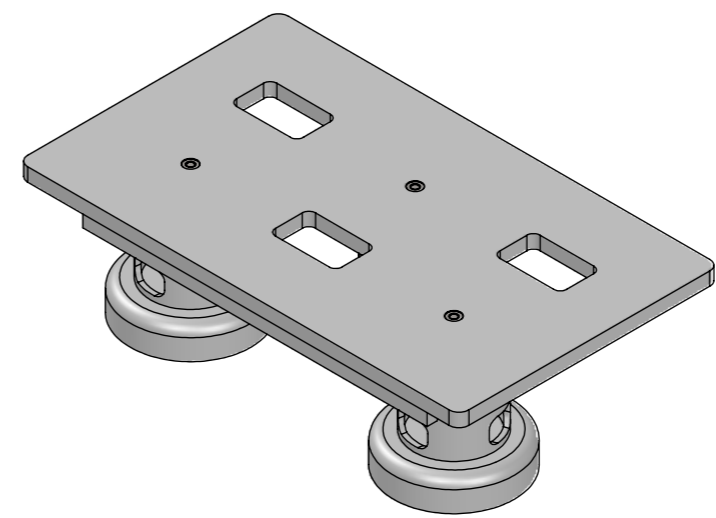
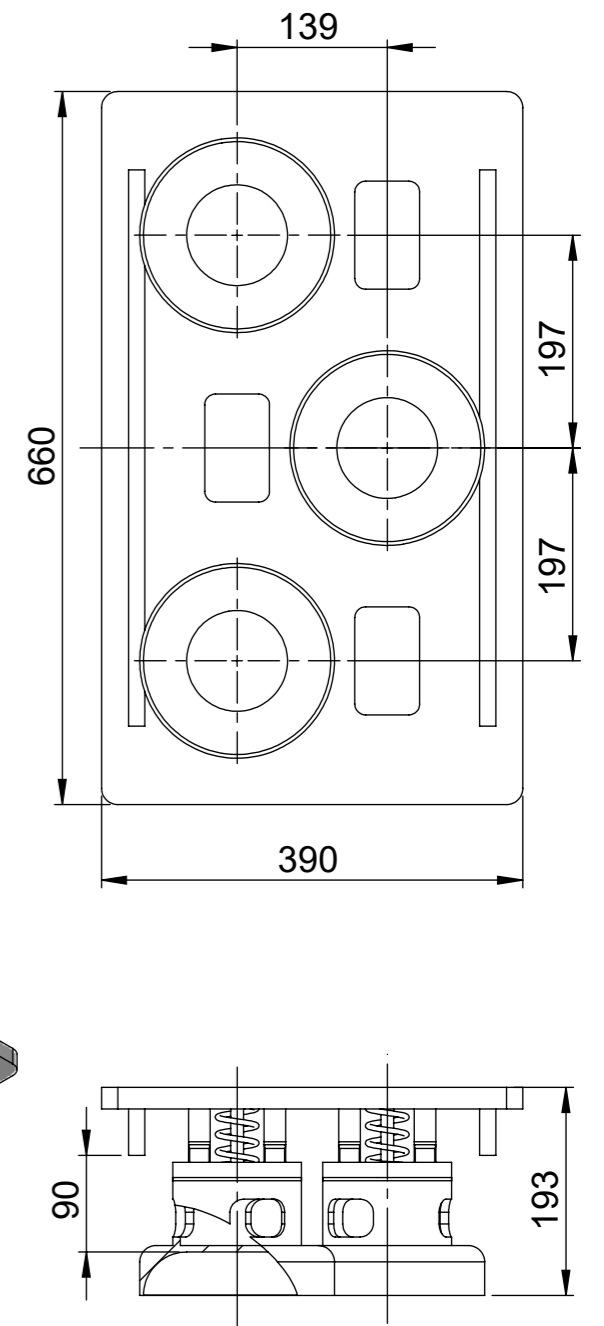

Limite de prensado

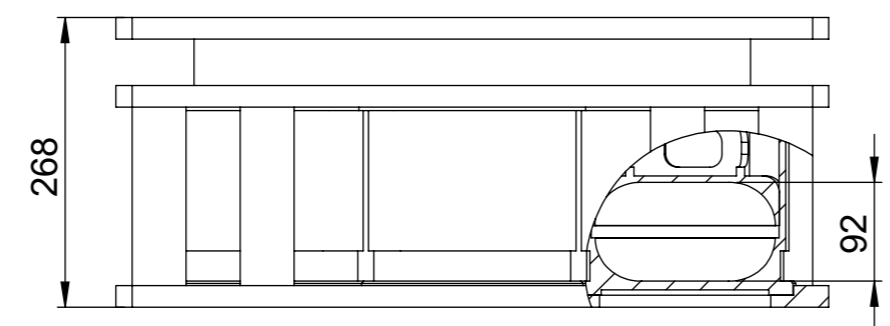

Tolerancias generales		Plano	
Medida nominal inferior	0 300	Multimolde circular de 3 unidades x (Ø180 x 180) mm	
Medida nominal superior	300 1000	Material	Peso
Tolerancia	±0.5 ±1	KUAL-HQ-PE-HD	20,4 kg
Escala	1:7	Denominación	 <small>AGEO CULZONI 2097 RAFAELA-SANTA FE ARGENTINA TE:+549-3492-504060</small>
		Ø180 x H180 x 3U	
Unidades en mm.	This drawing is our exclusive property and it may not be reproduced, copied or loaned in part or whole, without our written authority.		Este plano es propiedad exclusiva y no debe ser reproducido, copiado o prestado en parte o en su totalidad, sin nuestra autorización escrita.
A3			